

# Operating Instructions

---

## *Pirani Vacuum Gauges & Dual Set Point Controllers*

**0.01 to 100 mTorr ( $10^{-5}$  to 0.1 Torr)**

**1 to 2000 mTorr**

**.01 to 20 Torr**

**.01 to  $100 \times 10^{-3}$  mbar**

**.001 to 2.000 mbar**

**.01 to 20.00 mbar**

**.001 to 13.333 Pascals**

**0.1 to 200.0 Pascals**

**1 to 2000 Pascals**

---

# Contents

<b>INTRODUCTION</b> .....	<b>1</b>
Instruments Covered By This Manual .....	2
Vacuum Gauge Indicator .....	3
Portable Vacuum Gauge Indicator .....	3
Dual Set Point Controller .....	4
<b>SPECIFICATIONS</b> .....	<b>5</b>
<b>INSTALLATION</b> .....	<b>7</b>
Unpacking Instructions .....	7
Panel Mounting .....	8
Gauge Tube Installation .....	10
<b>OPERATING INSTRUCTIONS</b> .....	<b>11</b>
Readings On The Display .....	11
Setting the Control Points .....	12
Relay Output Connector Wiring .....	12
Analog Output Signal .....	13
Optional 4-20 mA and 0-5 or 0-10 VDC Output .....	14
Calibration .....	15
Zero & Span Adjustment Using Reference Calibrator .....	15
Setting Zero And Span Using Manometer .....	16
Cable Extensions .....	17
Three Position Gauge Tube Selector Switch Operation .....	18
<b>TECHNICAL DATA</b> .....	<b>19</b>
Troubleshooting .....	19
Gauge Tube Wiring .....	19
Changing Operating Line Voltage .....	20
Set Point Hysteresis .....	20
<b>WARRANTY AND RETURN PROCEDURE</b> .....	<b>22</b>
Warranty Statement .....	22
Return Shipment Procedure .....	22
<b>PARTS AND ACCESSORIES</b> .....	<b>23</b>
<b>DIMENSION DRAWINGS</b> .....	<b>24</b>
<b>VACUUM / DEHYDRATION CHART</b> .....	<b>26</b>

# 1. INTRODUCTION

---

The Vacuum Gauge Indicator and Dual Set-point Controller are compact vacuum measurement and control instruments that offer the precision and high resolution of digital electronics at the same price as analog controls. These instruments introduce a newly developed sensor which incorporates an up-scale trim to improve tracking ability. The extremely rugged sensor is constructed with a solid, inert, noble metal that maintains its characteristics over long periods.

Cooler operating temperatures, half that of thermopile gauges, enhances stability as does a unique temperature compensation network. Replacement gauge tubes are interchangeable and have time constants of less than 0.3 seconds for the 2000 mT and 20 Torr instruments. (The 100 mT instrument is slower.)

Both the indicator and controller instruments feature simple, single hole installation. A new panel mounting system permits easy installation of the gauges into panel cutouts originally designed for Hastings, Varian, Televac and other analog meters without modifications. The standard 20 Torr and 2000 mT gauge tubes have 1/8 inch NPT male thread or fit into quick connects sized for 1/8 inch pipe (0.405 inch dia.) The standard 100 mTorr tube has 3/4" O.D. smooth tubulation.

While the instruments are not completely immune to shock and vibration, they do not have a delicate analog meter and therefore are considerably more rugged than analog types and much more resistant to pump vibration.

## 1.1. Instruments Covered By This Manual

---

This manual covers the following instruments:

- **0.01 to 20 Torr indicator**
- **0.01 to 20 Torr indicator and controller**
  
- **1 to 2000 mT indicator**
- **1 to 2000 mT indicator and controller**
  
- **1 to 2000 mT portable, battery powered indicator**
  
- **0.01 to 100 mT indicator**
- **0.01 to 100 mT indicator and controller**

Each of the instruments is designed for a specific pressure range. With the exception of the range, all indicators operate in the same manner, and all controllers operate in the same manner.

The instruments must be paired with a gauge tube of the same range for proper operation. Replacement gauge tubes are matched so they are interchangeable (in the same range) without recalibration. Stainless steel gauge tubes are available for use with the .01 to 20 Torr and the 1 to 2000 mT instruments.

---

## 1.2. Vacuum Gauge Indicator

---

The indicator instruments are rugged, digital vacuum gauges. They are small, compact instruments that power a Pirani-type gauge tube which senses changes in pressure by measuring the thermal conductivity of the residual gases in the vacuum system. The sensors are made of an inert, noble metal that does not oxidize or corrode. The long-term life expectancy for the gauge tube is excellent if kept clean and free of oil or other evaporated contaminants from the vacuum system.

Your instrument is ready to operate as received. Simply install the gauge tube, connect the gauge tube cable, and plug the line cord into an AC power outlet to place the indicator in operation.

The instrument is powered from a 115 VAC or 230 VAC line as specified when ordering. Power consumption is about 1 Watt. Either 50 or 60 Hz power may be used.

A 10 foot long gauge tube cable is attached and extensions up to 500 feet (if using #18 wire) may be added without affecting calibration. See section on Cable Extensions for more information.

---

## 1.3. Portable Vacuum Gauge Indicator

---

The battery powered gauge is ready to operate as received. The gauge displays a vacuum pressure reading for approximately one minute each time the "ON" switch is pressed. An automatic shut-off circuit turns the display off in order to conserve battery life. The Tube Type Selector Switch can be set for Pirani tubes, such as the KJL or VRC D-2000; or alternatives for T/C tubes, such as the KJL-6000 or Hastings DV6R. The battery gauge reads vacuum in the range of 1 to 2000 mTorr with the Pirani tubes, or 1 to 200 mTorr with the T/C tubes. Press and hold in the "ON" button to check the charge level of the battery. Recharge the battery anytime the reading on the display drops below 960. The gauge can be charged continuously when not in use.

## 1.4. Dual Set Point Controller

---

The Dual Set Point Controller instruments are combination controller and indicator digital vacuum gauges. The controllers power a Pirani-type gauge tube which senses changes in pressure by measuring the thermal conductivity of the residual gases in the vacuum system. The sensors are made of an inert, noble metal that does not oxidize or corrode. The long-term life expectancy for the gauge tube is excellent if kept clean and free of oil or other evaporated contaminants from the vacuum system.

In addition to acting as a digital indicator, the Dual Set Point Controller instrument operates two control relays. Set point pressures are set from the front panel and displayed on the meter. Push-to-set switches simplify display of the set points. Relays have 3 amp contacts, form C, and are terminated in screw terminal connectors on the rear. The mating half of the relay connector is provided.

The instrument is powered from a 115 VAC or 230 VAC line as specified when ordering. Power consumption is about 2 Watts. Either 50 or 60 Hz power may be used.

A 10 foot long gauge tube cable is attached and extensions up to 500 feet (if using #18 wire) may be added without affecting calibration. See section titled, "Cable Extensions" for more information.

Installation of the controller is identical to the Digital Indicator except for wiring the relay connectors for the control action. This is described in the section titled, "Relay Output Connector Wiring."

## 2. SPECIFICATIONS

---

- **Pressure Range:** 0.01 to 100.00 mTorr, 1 to 2000 mTorr, 0.01 to 20.00 Torr, depending on designed range of instrument.
- **Calibration:** Air or Nitrogen.
- **Accuracy:** Better than 5% of value or:  
(for 100 mTorr gauges)  $\pm 0.03$  mTorr,  
(for 2000 mTorr gauges)  $\pm 3$  mTorr,  
(for 20 Torr gauges)  $\pm 0.03$  Torr,  
whichever is larger.
- **Set Point Range:** Full scale, equal to full scale range of instrument.
- **Set Point Repeatability:** 2 digits.
- **Analog Output:** 0 to 2.000 volts = 0-2000 mTorr into 2000 ohm load or higher; or 2.000 volts = 20.00 Torr; or 1.0000 volt = 100 mTorr. 2 pin connector included.
- **Gauge Tube:** Gauge tubes for 2000 mT and 20T have 1/8 inch NPT male thread or fit into quick connects sized for 1/8 inch pipe (0.405 inch dia.) 100 mTorr tube has 3/4 inch O.D. smooth tubulation.
- **Power Consumption:** Approx. 1 Watt for indicator, 2 Watts for Controller @ 115 VAC (4 Watts for 20 Torr models).
- **Relays:** SPDT 3 Amp @115VAC; non-inductive loads.
- **Temperature Effects:** (For 2000 mT): changes in ambient temperature between 0°C and 50°C change the reading less than 0.2 mT per °C at 50 mT; less than 4 mT per °C at 900 mT. (For 20 Torr): Changes in ambient temperature between 0°C and 50 °C change the reading less than 0.01 Torr per °C. (For 0.01 to 100 mT): Changes in ambient temperature between 0° C and 50° C change the reading less than 0.004 mTorr per °C at hard vacuum and 0.4 mTorr at 50 mTorr.
- **Line Power:** 115VAC, 50/60 Hz; 230 VAC optional at no additional cost.

- **Line Regulation:**  $\pm 20\%$  produces less than 1% change in reading.
- **Dimensions:** See drawing at back.
- **Mounting:** Panel mounting hardware is included with each gauge and controller.
- **Gauge Tube Cables:** 10 foot (305 cm) attached; 4 wire for 2000 mT and 100 mT, 6 wire for 20 Torr.
- **Extension Cables:** Change gauge tube cable length without recalibration. Extensions to 500 feet (150M) can be provided.
- **Relay Output:** 3 pin screw terminal connectors.
- **Line Cord:** 5 1/2 feet (170 cm) long.
- **Net Weight:** Indicator: 1 lb. 2 oz. (0.5 kgs);  
Controller: 1 lb. 6 oz. (0.6 kgs).
- **Shipping Weight:** Indicator: 2 lbs., 8 oz. (1.1 kg);  
Controller: 3 lbs. (1.3 kg).



---

## 3. INSTALLATION

---

### 3.1. Unpacking Instructions

---

The instruments and gauge tubes are carefully packaged to protect them during shipment. Use reasonable care when removing them from the shipping box.

Inspect the instruments and gauge tubes carefully when you receive them. Should either the instruments or the gauge tubes show any signs of damage, file a claim with the carrier immediately. Do not destroy the shipping container. It will be required by the carrier as evidence to support claims. Call the factory immediately for instructions on return and repair of the instruments.

Please fill out and return the Warranty Registration card so that we can register your instrument in our warranty records.

## 3.2 Panel Mounting

### 1/4 DIN Enclosure

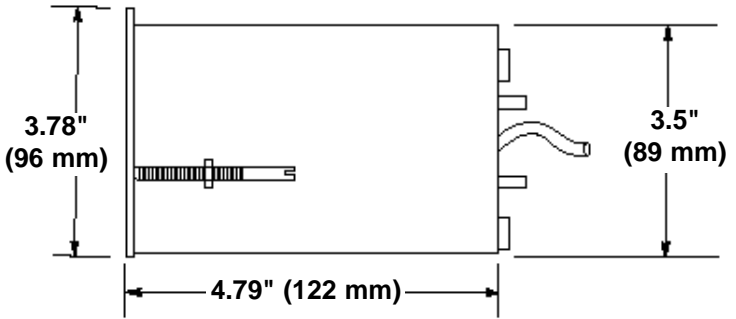

### Standard Mounting With Clip

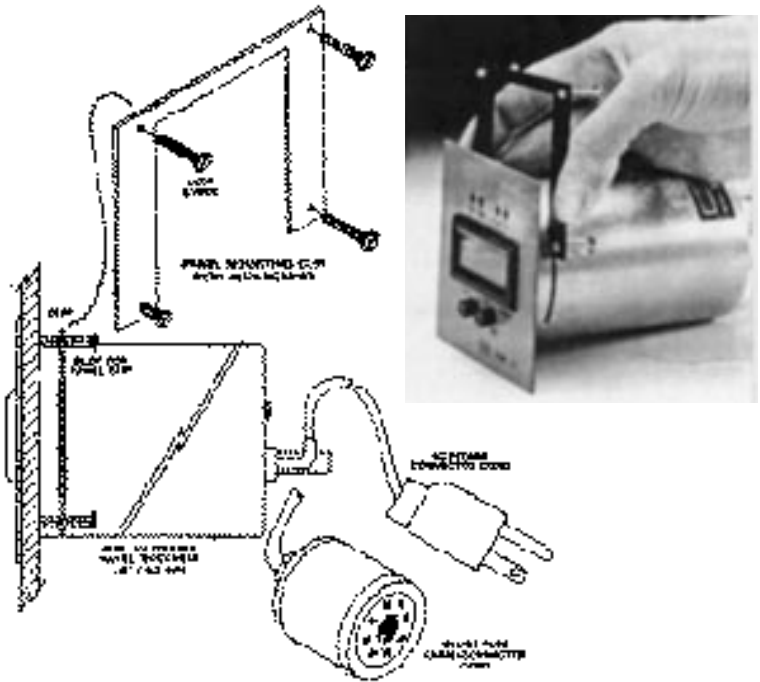

Both the digital indicators and dual set-point controllers mount in a single panel cut out.

Instruments provided in "standard enclosures" fit the same 2.75" (70 mm) round hole as used by Hastings, Televac, Lesker, Varian and other analog meter instruments. A 'U' shaped panel mounting clip is included with the instrument. Instruments provided in 1/4 DIN Enclosures fit a 92 mm x 92 mm cut out. Jack screws are included with 1/4 DIN instruments.

1. Loosen the screws and remove the 'U' shaped bracket from the standard enclosure or the 2 jack screws from the sides of the 1/4 DIN enclosure. Feed the power and gauge tube cables through the panel cutout and hold the instrument flush against the panel.

2. Reinstall the 'U' clip or jack screws. Lightly tighten (finger tight) the jack screws against back of the panel.

3. Adjust the front panel of the instrument to be square and level and tighten jackscrews snugly. Do not over-tighten.

4. Connect the power cord to an AC line power outlet of the appropriate voltage. Power consumption is approximately 2 watts.

5. Unless tagged, the instrument is shipped ready for operation on 115 VAC. If modified at the factory for 230/240 volt use, the 115 volt connector will be removed and the instrument tagged or marked for 230 volt operation. The customer will then be required to wire the power cord to his connector as follows:

Black = Line    White = Neutral    Green = Ground

6. After the gauge tube is installed in the vacuum system, connect the gauge tube cable to the gauge tube (See the following section, "Gauge Tube Installation", for more information on installing the gauge tube).

7. For controllers, please refer to the section titled, "Relay Output Connector Wiring" for information on connecting the output relays. Information on connecting the analog output signal for both the indicator and the controller instruments is contained in the section titled, "Analog Output Signal".

### 3.3. Gauge Tube Installation

---

1. Thread the gauge tube into a 1/8 inch NPT female fitting (or other fitting or flange as per your gauge tube), in the vacuum system. The preferred mounting is with the open end pointing down so as to be self draining to any condensation. However, mounting in any position is acceptable.

2. An appropriate thread sealant is required to insure that the threaded connection will not leak. Teflon thread tape may be used to seal the threads if care is used so it will not shred off and get inside the tube or vacuum system. It is better to use mini-seal or an epoxy sealer on the threads.

3. An excellent mounting system is to use an O-ring quick connect to install the gauge tube. These may be permanently installed in the system by welding, brazing or soldering. For the 100 mTorr gauge tube a 3/4" quick connect is required. The quick connects are available from vacuum equipment suppliers such as the Kurt Lesker Co. (1-800-245-1656).

4. Another alternative is to use quick flange adaptors. Gauge tubes can be ordered with QF, VCR, and Mini-Conflat flanges.

## 4. OPERATING INSTRUCTIONS

### 4.1. Readings On The Display

When the power is applied and the gauge tube connection is made, your instrument is in operation. After a short time period for stabilization, the digital display will show a reading of vacuum pressure.

At atmospheric pressure, and at pressures above the designed range of the instruments, the display will show a "1" with the other digits blanked out. This indicates saturation.

The 100 mTorr instruments saturate at 110 mTorr and the display shows a blinking "00.00" to indicate overrange. Although the 100 mTorr analog output will still increase in value from 1.10V @ 110 mT to 1.66V @ atm., the meters are only accurate at 100 mTorr and below.

After saturation, when the pressure drops below full scale, the instrument will resume reading vacuum pressure.

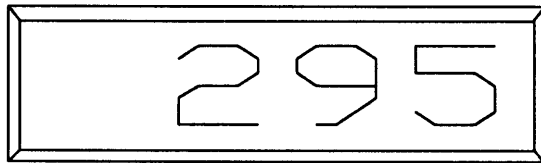

NORMAL DISPLAY

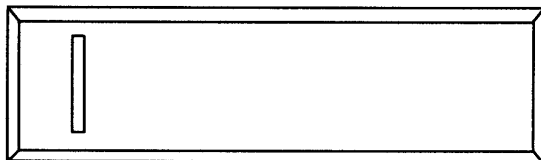

SATURATION

## 4.2. Setting the Control Points

To set the control points, press in either the Low or High “Push To Display” push-button on the front panel. This will display that set point on the digital meter. Adjust the multi-turn pot that corresponds to that set point until the desired pressure for the control action is read on the meter. The set point adjustment pots are located on the front panel on either side of the LEDs. Release the “Push To Display” push-button and the instrument will again read pressure.

If the meter saturates and reads 1 xxx with the right-most digits (xxx) blanked out, the control pressure setting is still correctly displayed when either of the push-buttons are depressed.

The LED’s show control action in the following manner:

- Relay energized, LED is ON ; de-energized, LED is OFF
- Relays are de-energized when pressure is above the set-point (on atmospheric pressure side of set point.)
- Atmospheric pressure = de-energized = loss of power
- “NORMAL” = de-energized relay

## 4.3. Relay Output Connector Wiring

Contact Rating:

- 3 amps, 120 VAC, resistive
- 1.5 amp, 230 VAC, resistive
- 1.5 amp, 28 VDC, inductive

Gently pull the connectors and they will detach from their sockets for wiring. Plug back in when connections are made. The “Low” set point relay is on the right side when looking at the instrument from the rear.

**Relay Connectors On Rear Of Controller**

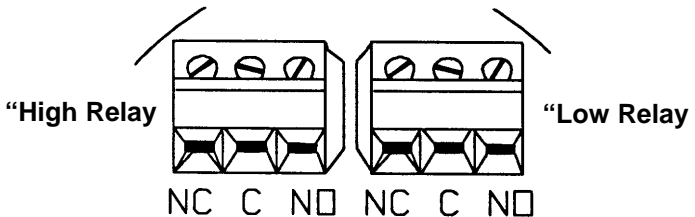

## 4.4. Analog Output Signal

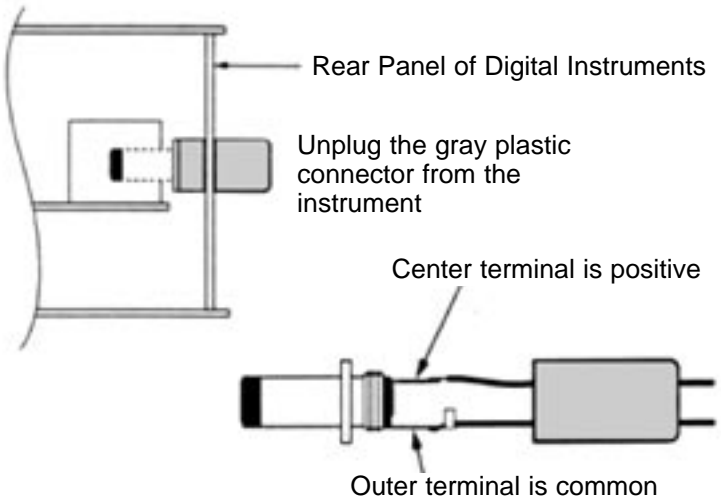

Vacuum gauges are shipped with a removable connector for analog output plugged into the rear panel of the instrument. Follow the steps below to wire the connector for output to remote recorders, dataloggers, etc.

1. Unplug the gray connector from the rear panel.
2. Unscrew the gray plastic connector cover.
3. Feed your analog output wires through this cover.
4. Solder the positive wire to the center terminal.
5. Solder common or negative wire to the outer terminal.
6. Reinstall the connector cover and plug into the gauge.

The output signal is zero at hard vacuum ( $10^{-4}$  Torr or lower) and increases to 2.000 volts @ 2000 mTorr; or 2.000 volts @ 20.00 Torr; or 1.000 volt @ 100 mTorr, depending on the specific range of the instrument.

The signal continues to increase above this level but it is not linear and is not intended for use by the customer above 2.000 volts for the 2000 mT and 20 Torr instruments, or above 1 volt for the 100 mTorr instruments.

Since volts and pressure units are scaled together, this signal is pre-calibrated at 1 mTorr=1mV, from 1 to 2000 mTorr. Output load should be 2000 ohms or higher.

---

#### **4.4.1 Optional 4-20 mA and 0-5 or 0-10 VDC Output**

---

Gauges provided with an optional output are built in 1/4 DIN size cabinets which mount in 92 mm square panel cut-outs.

On the rear panel of the instrument you will find a section identified as “analog output” which includes the zero and span adjustment potentiometers and a male connector for the 4-20 mA, 0-5 or 0-10 VDC outputs.

Unplug this connector and unscrew the gray plastic shroud. Feed a shielded wire through this shroud and solder the shield to the outside lug and the center conductor to the inner lug. The shield is the circuit common or zero and the center conductor is 20 mA, 5 or 10 volts. The output is floating. The resistance in the mA output loop can be up to 1000 ohms. The 5 or 10 VDC output should have loads of 2000 ohms or higher.

Before being shipped from the factory the 4 mA is scaled to the low end of the instrument range (or zero pressure) and the 20 mA is adjusted to coincide with the full scale instrument reading of 100mT, 2000mT, 20.00 Torr or 1500 Torr. Instruments built with 5 or 10 VDC outputs are also scaled before shipping. Rear panel zero and span adjustments are provided with all output ranges should fine tuning in the field be required.

The standard analog output voltage signal described in section 4.4 of the manual continues to function even when these optional outputs are provided.

---

### **4.5. Calibration**

---

There are only 3 calibration adjustments that are normally necessary to re-standardize the instrument. One is an offset adjustment. The other two amount to a “zero” adjustment for hard vacuum, and a span adjustment to set up scale tracking at some known pressure. There are two methods for setting these adjustments. The methods are described in the following two sections.



## 4.5.1 Offset & Span Adjustment Using Reference Calibrator

Purchase a reference gauge tube calibrator from the manufacturer or your supplier. The calibrator is marked with the three proper settings for adjustment of zero, span, and offset. A simple toggle switch selects the "zero" and "span" and "offset" circuits so that you can make the proper adjustments using the associated zero, span and offset pot. All three adjustment pots are located on the rear of both the indicator and controller instruments. The pots are clearly marked.

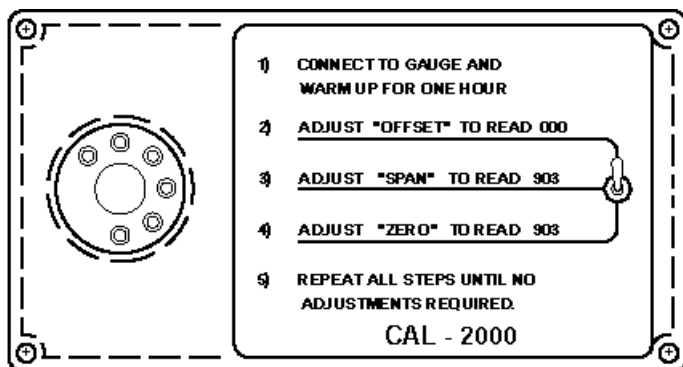

Make the adjustments in the following sequence:

- 1) Adjust offset (A calibrator must be connected to the gauge to make this adjustment.)
- 2) Adjust zero
- 3) Adjust span

Please note that the "zero" adjustment is not truly a zero setting, but a power adjustment at which a gauge tube will read zero when pumped to a pressure below its sensitive range. This is usually referred to as "hard vacuum." For the gauge tubes supplied with these instruments, hard vacuum is any pressure one decade below the lowest reading for that range, or lower.

## 4.5.2. Setting Zero And Span Using Manometer

This method requires a high vacuum system and a precision calibration “standard” such as a capacitance manometer. If these are not available, use the reference tube technique described previously. The procedure below lists ranges and settings for a 2000 mTorr instrument as an example.

To set zero and span using a capacitance manometer for the 2000 millitorr instrument requires a high vacuum system capable of pressures less than  $1 \times 10^{-4}$  Torr, and a precision calibration “standard” such as a capacitance manometer with a 1 Torr or 10 Torr head.

First, pump the tube to hard vacuum and hold it there for about 20-30 minutes to thoroughly outgass the tube. Adjust the zero adjustment until it reads 000 on the meter.

Second, raise the pressure to 900 mTorr (for instruments of other ranges choose a pressure near mid-scale), and hold that pressure constant. Adjust the span adjustment pot to read the same pressure as the calibration standard. The instrument is now calibrated. If the span adjustment was far off, repeat the procedure.

The span adjustment permits you to trim the instrument for precise indication at a critical pressure, increasing the absolute accuracy at that point, although possibly sacrificing tracking at other points on the scale. The 900 mTorr point is best on a 2000 mT instrument for all-around average tracking throughout the 1 to 2000 mTorr range.

- ›› **NOTE:** If a reference tube or precision calibration standard are not available, but you feel there is a need to calibrate the instrument, then pump to hard vacuum and set the zero only. Do not attempt to make the reading agree with other typical analog thermocouple or Pirani gauges upscale as this will result only in degraded performance of this gauge.

## 4.6. Cable Extensions

The indicator and controller models are unique in their ability to change cable lengths without requiring recalibration. Typically, for a 2000 mTorr instrument, a 500 foot cable of #18 wire may be added with less than 1 mTorr error.

If factory cables are purchased with the instrument, it will be calibrated with that cable. Customers making their own cables may do so to any length, provided the wire resistance is kept at 3.2 ohms or less per lead, e.g. 500 feet of #18 wire is 3.19 ohms. We suggest using 8-wire #22 for up to 200 foot lengths. Beyond this, we recommend going to larger size wire. Wire all pins since all are used for the various tube types (except pin 2). Be sure to make good solder joints. Crimped connections are not recommended.

For long cable extensions, shielded wire may be desirable and is a good precaution against stray electrical noise. Connect the shield to pin 1, which is circuit common. Extension cables may be purchased from the manufacturer in several standard lengths. If you wish to make your cable extensions, see the pin out details below for your specific instrument range.

- 100 mTor: 4 wires, pins 1, 5, 6, 8
- 2000 mTorr: 4 wires, pins 1, 4, 5, 8
- 20 Torr: 6 wires, pins 1, 3, 5, 6, 7, 8

<b>Gauge Tube Wiring Reference Table</b>						
(Wire Color of Conductors in Extension Cable Shown in Parenthesis)						
Pin #	2000 mT		20T		100 mT	
	Function	Color	Function	Color	Function	Color
1	GND	(BLACK)	GND	(BLACK)	GND	(BLACK)
2	—		—		—	
3	—		PWR	(RED)	—	
4	PWR	(RED)	—		—	
5	SIG	(GREEN)	SIG	(GREEN)	SIG	(GREEN)
6	—		GAIN RES +	(BLUE)	PWR	(RED)
7	—		GAIN RES GND	(BROWN)	—	
8	REF	(WHITE)	REF	(WHITE)	REF	(WHITE)

## 4.7. Three & 5 Position Gauge Tube Selector Switch Operation

Use the 3 or 5 Position Gauge Tube Selector Switch as an accessory with the indicator instruments. Plug the male connector of the 3 or 5 Position Selector Switch into the gauge tube cable of the indicator. Then connect one, two, three, four, or five (depending on model) separate gauge tubes to the gauge tube cables of the switch.

The front panel switch settings of 1, 2, 3 (4, 5) correspond to the gauge tube #1, gauge tube #2, gauge tube #3 (#4, #5) marked on the rear panel identifying the gauge tube cables.

The Selector Switch is intended for use with the indicator instruments. If used with the Dual Set Point Controllers, the signal may trip relays when switching between gauge tubes. If that does not present a problem with your application in using the controller, then the 3 or 5 position switch may be used with the controller also.

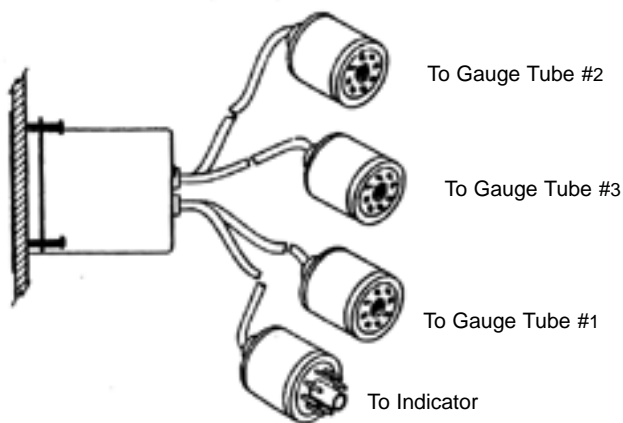

**Color Codes For Extension Cables and Switching Attachment Cables**

Pin 1	BROWN	Pin 5	GREEN
Pin 2	—	Pin 6	BLUE
Pin 3	ORANGE	Pin 7	BLACK
Pin 4	YELLOW	Pin 8	WHITE

## 5. TECHNICAL DATA

### 5.1. Troubleshooting

It is strongly recommended that every customer keep a small stock of spare gauge tubes on hand along with a Reference Gauge Tube Calibrator.

Always try a new tube before considering circuit failures. The Reference Gauge Tube Calibrator may be connected to the circuit to prove whether the problem is a gauge tube or circuit failure. If the instrument works properly with the Reference Gauge Tube Calibrator circuit, then gauge tube failure is a certainty.

### 5.2. Gauge Tube Wiring

The gauge tube can be checked with an ohmmeter between pins 1 and 5 to verify that the sensor is good. Generally, the reading is less than 2.5 ohms if good; 900 ohms if the sensor is broken.

The actual readings for each type of tube should be as follows:

	SENSOR PINS 1 TO 5 BLACK AND GREEN WIRE APPROXIMATE RESISTANCE	HEATER WHITE AND RED WIRES
100 mT	2.4 Ohms	Pin 6 To 8
2000 mT	2.1 Ohms	Pin 4 To 8
20 Torr	1.3 Ohms	Pin 3 To 8

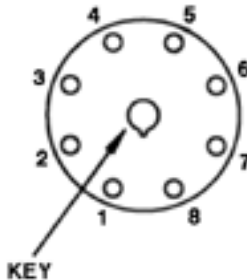

### 5.3. Changing Operating Line Voltage

The operating voltage for instruments can be changed in the field by changing the connection across four pads on one of the circuit boards. For access to these pads, remove 2 screws in rear of the cylindrical outer cover. Slide the cover back, completely away from the circuit boards. Locate the four pads on the edge of the circuit board where the power cord comes to the circuit board.

Instruments set for operation at 115 VAC have jumpers connecting the outside pairs of the four pads. Instruments set for operation at 220 VAC have jumpers connecting the inside pair of the four pads. See illustration below.

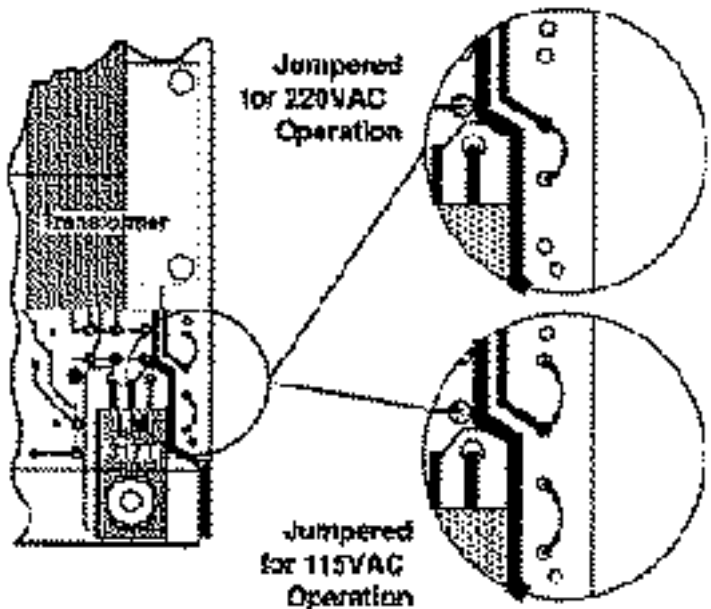

Clip the jumpers close to the pads and install new jumper(s) to change to the desired configuration.

### 5.4. Set Point Hysteresis

In some vacuum or pressure control systems the system performance can be improved and "chatter" around the set point eliminated if some amount of hysteresis is added to the set point control circuit.

Our standard gauges are shipped without a resistor in the R-5 position in the high relay circuit and without a resistor in the R-13 position in the low relay circuit. This produces about  $\pm 1$  digit hysteresis.

Installing resistor values as shown in the table will increase the hysteresis. Keep in mind that these are digits, not mTorr, Torr, or any other pressure unit.  $\pm 10$  digits is  $\pm 10$  mTorr on a 2000 mTorr full scale instrument. On an instrument with full scale of 20.00 Torr  $\pm 10$  digits is  $\pm 10$  Torr. The set point is always in the middle of the hysteresis band. For example, a 20.00 Torr gauge with a set point of 15.00 Torr and a hysteresis of  $\pm 10$  digits would cause the relay to change state at 15.10 Torr and 14.90 Torr.

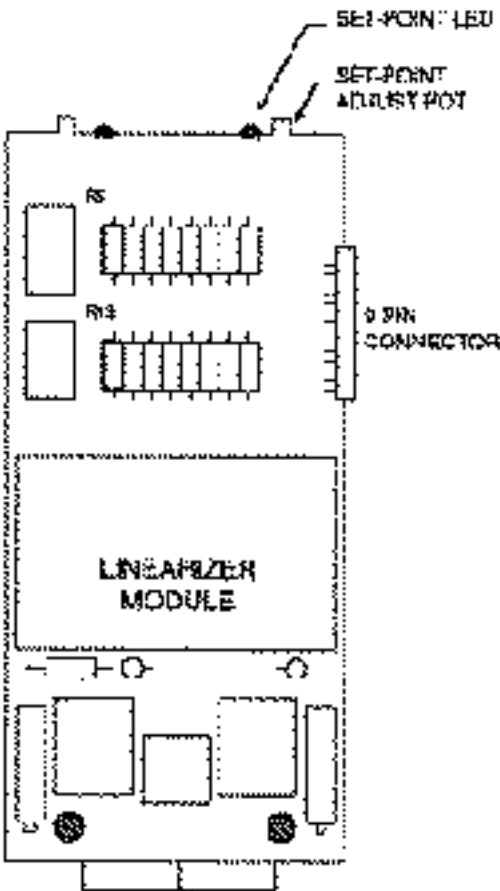

R-5 and/or R-13 Resistors	
Resistance Value	Hysteresis Band Width
2 megohm	$\pm 2$ digits
1 megohm	$\pm 3$ digits
700 K ohm	$\pm 5$ digits
500 K ohm	$\pm 7$ digits
365 K ohm	$\pm 10$ digits
250 K ohm	$\pm 15$ digits
200 K ohm	$\pm 20$ digits
160 K ohm	$\pm 50$ digits
80 K ohm	$\pm 100$ digits

---

## 6. WARRANTY AND RETURN PROCEDURE

---

### 6.1. Warranty Statement

---

The manufacturer warrants all instruments for a period of two years against defects of material and workmanship subject to the terms and conditions set forth below:

1. The warranty is in effect at date of shipment from the manufacturer to the original purchaser.
  2. Expendables such as gauge tubes, etc. are not covered by this warranty.
  3. Claims against this warranty for replacement parts and/or service shall be limited to defects in materials and workmanship. Malfunctions attributable to neglect, abuse, or repair and operational procedures not specifically recommended by the manufacturer are not warranted.
  4. Service repairs and/or piece part replacement shall be warranted for a period of ninety (90) days commencing on date of return shipment or until expiration of the remaining term of original instrument warranty, whichever is later.
  5. The manufacturer shall not be liable for consequential damages nor for labor, loss or expenses directly or indirectly arising from use of their products or equipment.
  6. This warranty does not apply to shipping damage. Claims for damage incurred while products are in transit rest with purchaser. Said claims are to be levied against the carrier.
  7. Amendments, assumed corollaries or statements contrary to the terms of this warranty shall not be binding upon the manufacturer unless stated in writing and approved by an officer of the manufacturer.
- 8. THE MANUFACTURER MAKES NO OTHER WARRANTY, EXPRESSED OR IMPLIED, AND MAKES NO WARRANTY OF MERCHANTABILITY OR OF FITNESS FOR ANY PARTICULAR PURPOSE.**
9. Warranty service is F.O.B. point of manufacture. All transportation charges to and from the manufacturer's plant shall be the responsibility of the purchaser.

### 6.2. Return Shipment Procedure

---

If repairs are required, return the instrument with cables and gauge tube to the manufacturer, pre-paid. Include a purchase order and statement of the nature of the problem.



## 7. PARTS AND ACCESSORIES

### Gauges and Controllers

0.01 - 100 mTorr Dual Set Point Controller.....	902005
0.01 - 100 mTorr Indicator.....	902006
1 - 2000 mTorr Dual Set Point Controller.....	902001
1 - 2000 mTorr Indicator.....	902002
1 - 2000 mTorr Portable, Battery Powered Indicator.....	902017
0.01 - 20 Torr Dual Set Point Controller.....	902015
0.01 - 20 Torr Indicator.....	902016
1 mTorr- 20 Torr Dual Range Indicator.....	902025
1 - 1500 Torr Dual Set Point Controller ( $\pm 1$ Torr).....	902019
1 - 1500 Torr Indicator ( $\pm 1$ Torr).....	902020
30" Hg - 100 PSIG Dual Set Point Controller.....	904001
30" Hg - 100 PSIG Indicator.....	904002
.01 - 20 PSIG Dual Set Point Controller.....	904005
.01 - 20 PSIG Indicator.....	904006
.01 - 200 PSIG Dual Set Point Controller.....	904003
.01 - 200 PSIG Indicator.....	904004

### Gauge Tubes, Sensors, and Accessories

0.01 to 100mTorr GaugeTube 3/4"OD Tubulation.....	912018
0.01 to 100 mTorr Gauge Tube KF Flange .....	912037
0.01 to 100 mTorr Gauge Tube,1.33 in Conflat, non-rotatable.....	912160
0.01 to 100 mTorr Gauge Tube, 2.75 in Conflat, non-rotatable.....	912038
0.01 to 100 mTorr Gauge Tube, 15 mm Diameter Tube.....	912101
1 to 2000 mTorr Gauge Tube with 1/8 in. NPT Male Thread.....	912001
1 to 2000 mTorr Gauge Tube with KF-16 Flange .....	912005
1 to 2000 mTorr Gauge Tube with 1.33 in Conflat, non-rotatable...	912067
1 to 2000 mTorr Gauge Tube with VCR-4 Fitting.....	912068
1 to 2000 mTorr Gauge Tube,15 mm Diameter Tube.....	912102
1 to 20 Torr Gauge Tube with 1/8 in. NPT Male Thread.....	912011
1 to 20Torr Gauge Tube with KF-16 Flange .....	912072
1 to 20 Torr Gauge Tube with 1.33 in Conflat, non-rotatable.....	912073
1 to 20 Torr Gauge Tube with VCR-4 Fitting.....	912074
1 to 20 Torr Gauge Tube,15 mm Diameter Tube .....	912103
All Stainless Steel Gauge Tubes for outdoor applications or wherever the use 304 SS is appropriate. All wetted parts as well as an external parts and connector pins are 304 SS. . . .Add "SS" prefix to any tube P/N. Extension Cable with Connectors for All Tubes (not wide range)....	912063
3 Position Gauge Tube Selector.....	902027
Gauge Tube Baffle, Brass 1/8 NPT.....	912007
1 - 2000 mTorr Vacuum Gauge Calibrator.....	912008
.01 - 20 Torr Vacuum Gauge Calibrator.....	912009
100 mTorr Vacuum Gauge Calibrator.....	912019
Single Bench Mount Cabinet (fits instruments of any span).....	V805002
Double Bench Mount Cabinet (accommodates 2 instruments or instrument & 3 pos. selector.....	V805003
1/4 Din Bezel Kit (for 92 mm DIN cutout, fits any instrument).....	V805004
Handle for Bench Mount Cabinet.....	V805005
Lined Carry Case for Portable Gauge.....	912028

### VRC-6M & VRC 6R Gauge Tubes Interchangeable with Teledyne-Hastings DV-6 Tubes

VRC-6M Gauge Tube, All Metal 1/8 NPT.....	912086
VRC-6M-KF 16 Gauge Tube, All Metal, KF-16 Flange.....	912096
VRC-6M-VCR-4 Gauge Tube, All Stainless Steel, VCR-4.....	912082
VRC-6R Gauge Tube, All Stainless Steel,1/8 NPT.....	912087
VRC-6R-KF 16 Gauge Tube, All Stainless Steel, KF-16 Flange.....	912098
VRC-6R-VCR-4 Gauge Tube, All Stainless Steel, VCR-4.....	912099

## 8. DIMENSION DRAWINGS

### Indicators and Controllers Are Available In 2 Enclosure Styles

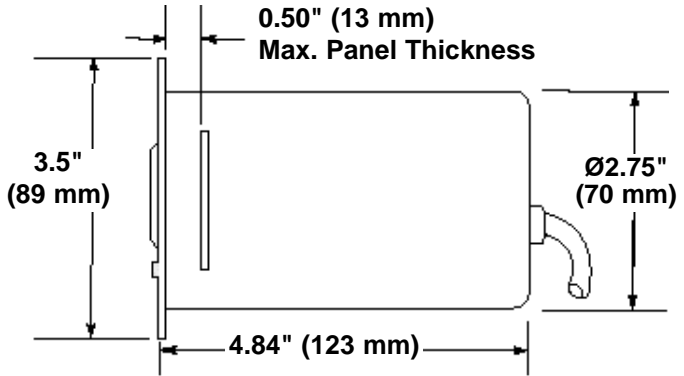

#### Standard Enclosure

The standard enclosure has a cylindrical body that fits the same 2.8 inch diameter panel cutout as Hastings, Televac, and other gauges. Panel mounting hardware is included with standard enclosure.

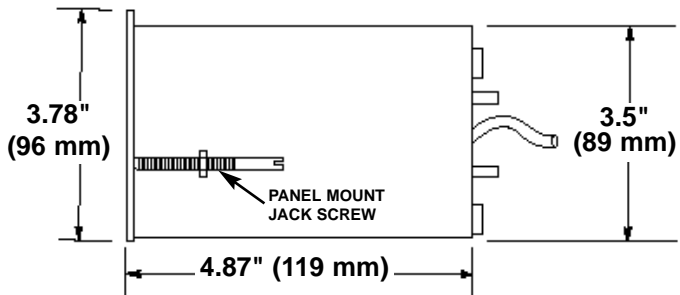

#### 1/4 DIN Enclosure

The 1/4 DIN enclosure is rectangular and fits the standard 92mm x 92mm panel cutout. Panel mounting jackscrews are included with 1/4 DIN enclosure.

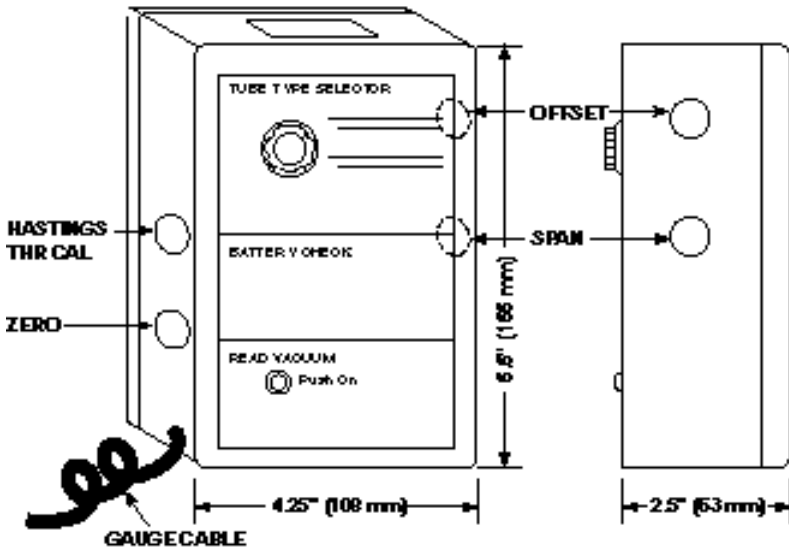

## 1 To 2000 mTorr Portable Battery Gauge

To adjust Zero, Span and Offset use 2000 mT calibrator P/N # 912008  
 To adjust THR use 1000 mT calibrator P/N 902114

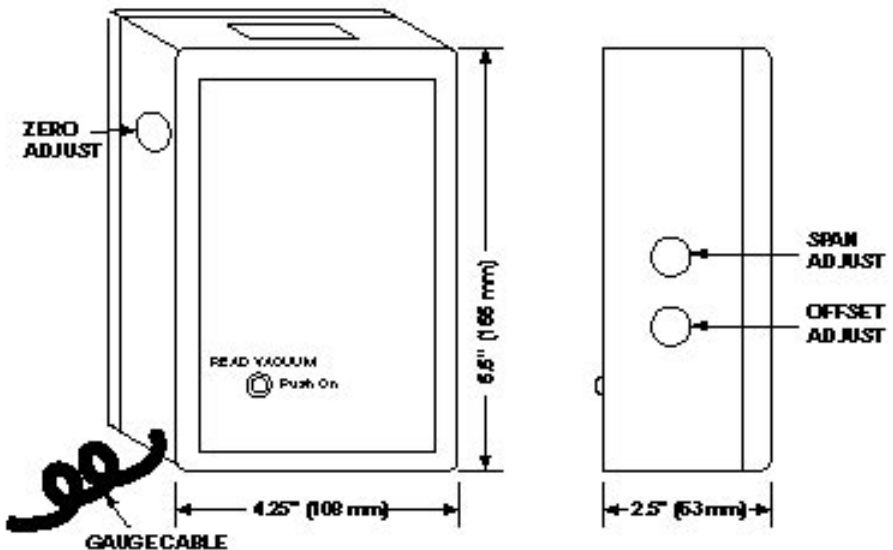

## 0.01 to 20.00 Torr Portable Battery Gauge

To adjust Zero, Span and Offset use calibrator P/N # 912009

## Vacuum / Dehydration Chart

Boiling Point of Water		Inches Hg Vacuum* (Gauge)	MICROMMS (milliTorr) (Absolute)	Torr & mm Hg (Absolute)	mmbar (Absolute)	Pascal (Absolute)	PSIA (Absolute)
212 °F	100 °C	0	760,000	760	1013	101,327	14.70
200 °F	93.3 °C	6.50	600,000	600	800	80,032	11.50
		15.00	400,000	400	533	53,349	7.50
125 °F	51.7 °C	25.00	100,000	100	133.3	13,326	2.00
100 °F	37.8 °C	28.00	50,000	50	67	6,666	.97
72 °F	22.2 °C	29.00	20,000	20	27	2,666	.39
52 °F	11.1 °C	29.46	10,000	10	13.3	1,333	
34 °F	1.1 °C	29.69	5,000	5	6.6	666.6	
		29.74	1,000	1	1.33	133.3	.02
		29.93	1	.001	.0013	.1333	.0005

\*Because "Inches Hg" is a "Gauge" measurement (which uses atmospheric pressure as its reference), the readings at "hard vacuum" change with the local barometric pressure.

---

**Vacuum Research Corporation • 2419 Smallman Street • Pittsburgh, PA 15222 USA**  
**Phone: (800) 426-9340 • (412) 261-7630 • FAX: (412) 261-7220**  
**e-mail: [vrc@vacuumresearchcorp.com](mailto:vrc@vacuumresearchcorp.com)**